

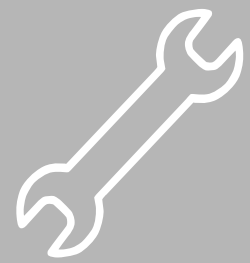

Walters & Wolf



 **EXAMGLIDE**TM
BY WALTERS & WOLF



Highly Customizable
(From Hardware to Wall Widths)



ADA Compliant



Environmentally Friendly Design



**UL 1784
Smoke & Draft
Certified**



**Lead Lined
Assemblies Available**



Streamline Your Space With ExamGlide

Our ExamGlide design is adaptable for a multitude of applications including patient rooms, exam rooms, and those difficult spaces without room for a swing door.

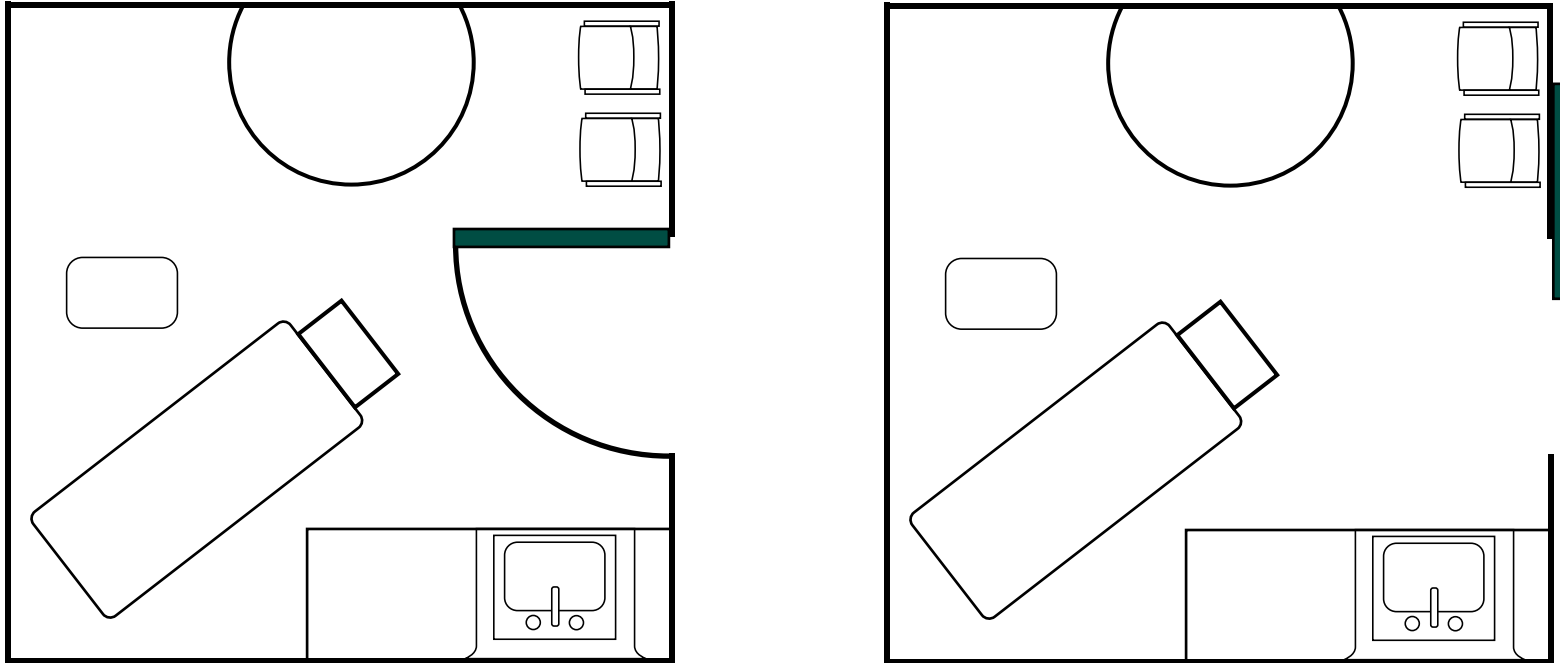

**Work with
people
you can trust.**

Walters & Wolf Interiors has been creating and perfecting its interior design products for over 45 years. Our team not only manufactures our products, we have a local installation team, project management team, inspection team, and product specialists on standby to help facilitate every project from start to finish. We care deeply about the functionality of our products because we install them.

Tested & Perfected

A Product created by Builders



Space Saving

ExamGlide sliding technology creates a seamless and spacious solution for every workplace environment.



Hidden Floor Guide

No floor track for potential tripping injuries to occur.



Soundproofing

Tested and approved for an STC rating of up to 41. We are constantly experimenting and formulating new designs to gain higher STC ratings in the future.



Card Reader Capabilities

A variety of electrified hardware implementations available.



Securable

Secure your spaces with electrified locks, mortise locks, and more.



Customizable

The doors you order are crafted & tested by our team of experts. We are builders, constantly improving and developing our products to fit your needs.

Door Options



Wood/ Wood Veneer

Our team has expert level experience installing a multitude of wood door types. Consult us to find the wood that best suits your facility's needs.



Aluminum

Doors made with lightweight bacteria resistant aluminum.



Painted Finishes

Consult with us to find the perfect match on your interior doors.

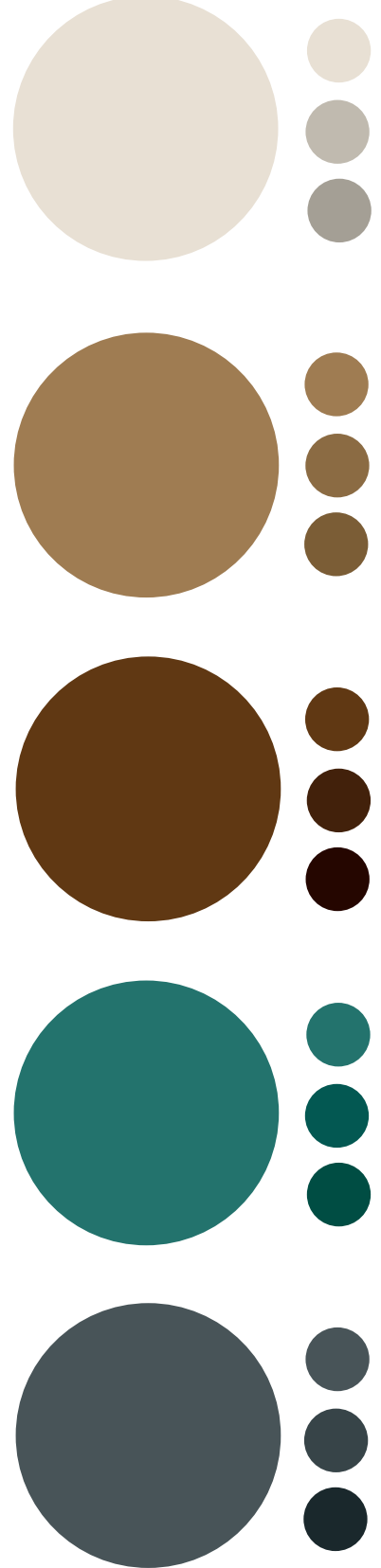

Soundproofing Capabilities

Glass Notes:

STC 37 = 7/16" Laminated glass required in door & sidelite.

STC 38 = 9/16" Laminated glass required in door & sidelite.

STC 39 = 11/16" Laminated glass required in door & sidelite.

Door only (VT STC-41 SG4):

STC 40 = Flush wood door

STC 41 = Flush wood door

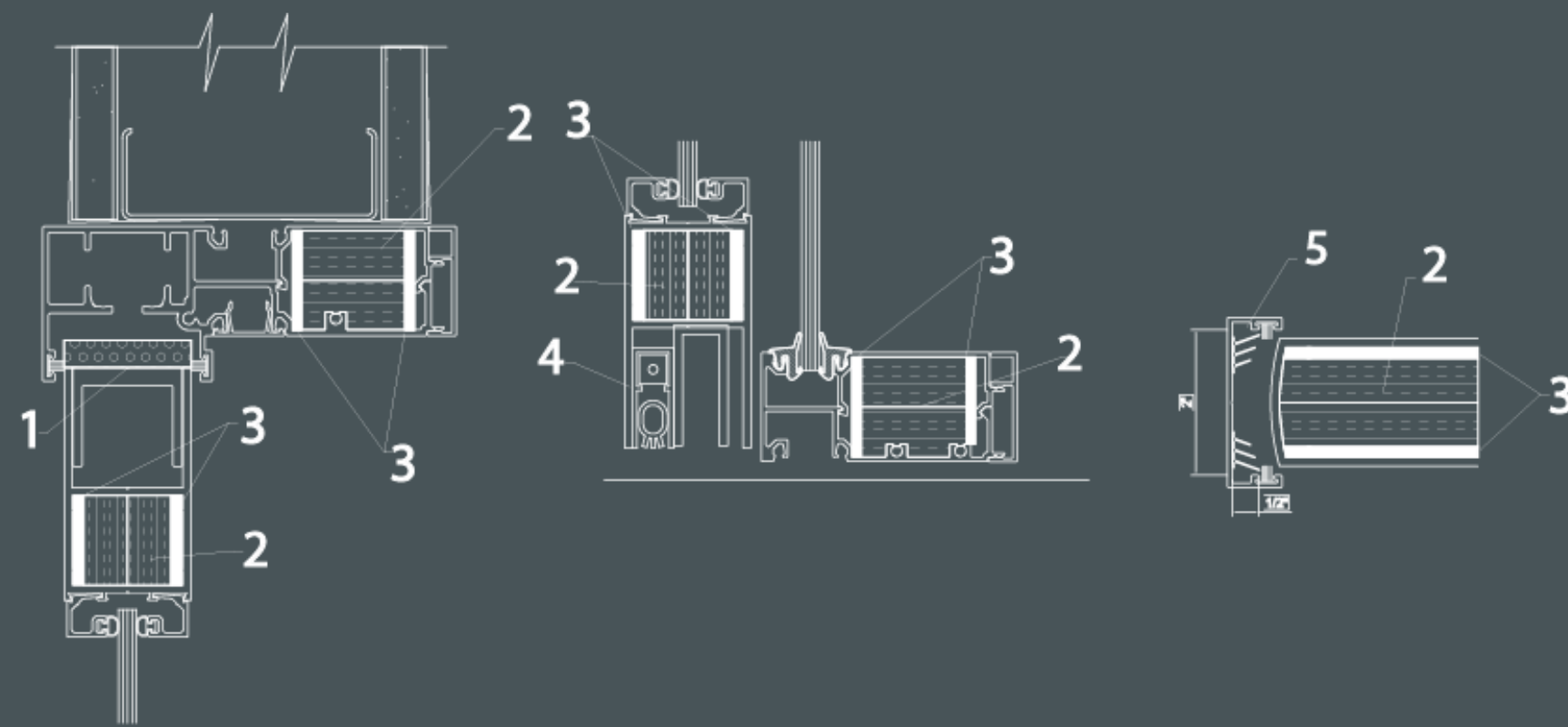
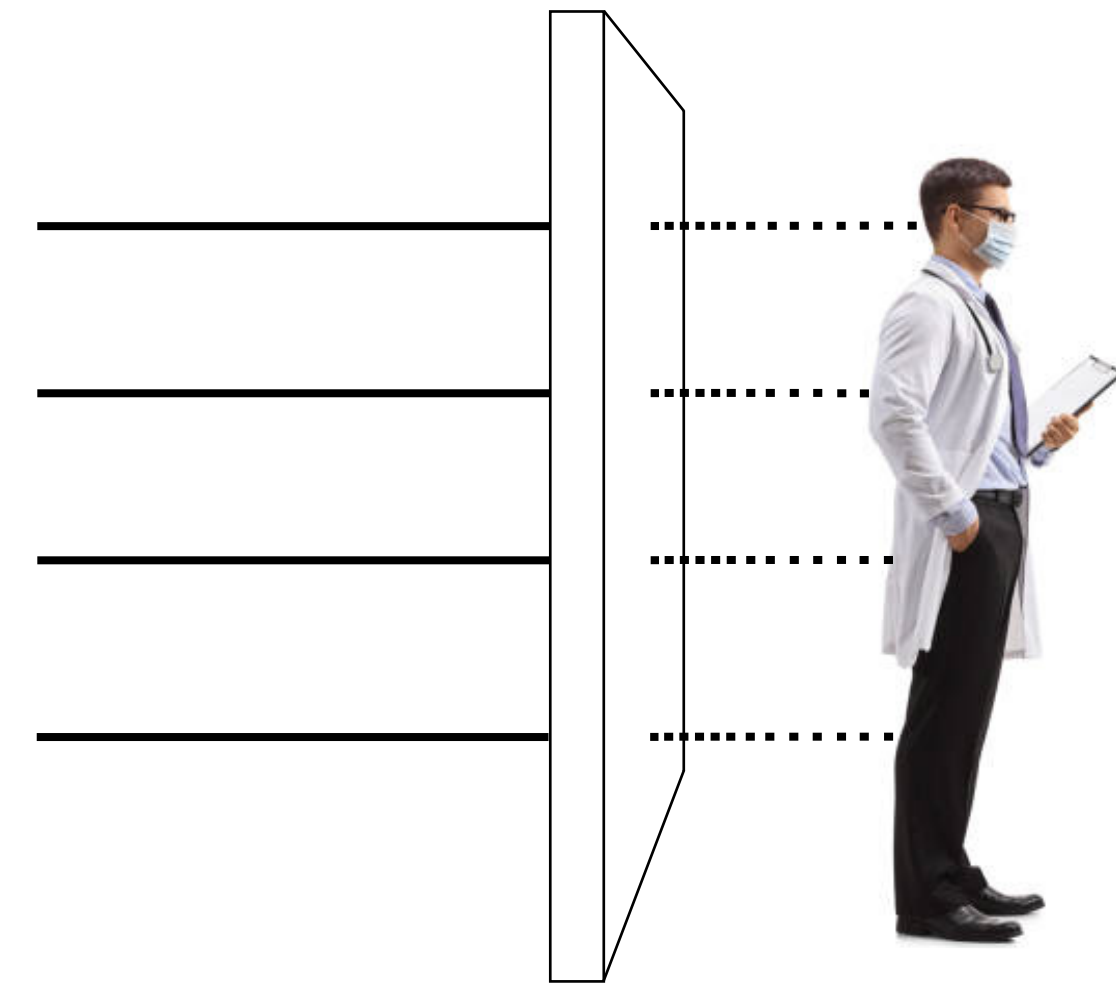

- 1 3/4" x 3/8" light grey substrate with grey Tuftane facing.
- 2 2" Thick compressed Roxul
- 3 1/8" 2lbs mass loaded vinyl
- 4 NGP 780 VA automatic door bottom
- 5 Pemko S773B adhesive gasketing
- 6 Pemko S88B adhesive gasketing
- 7 Pemko S771B adhesive gasketing

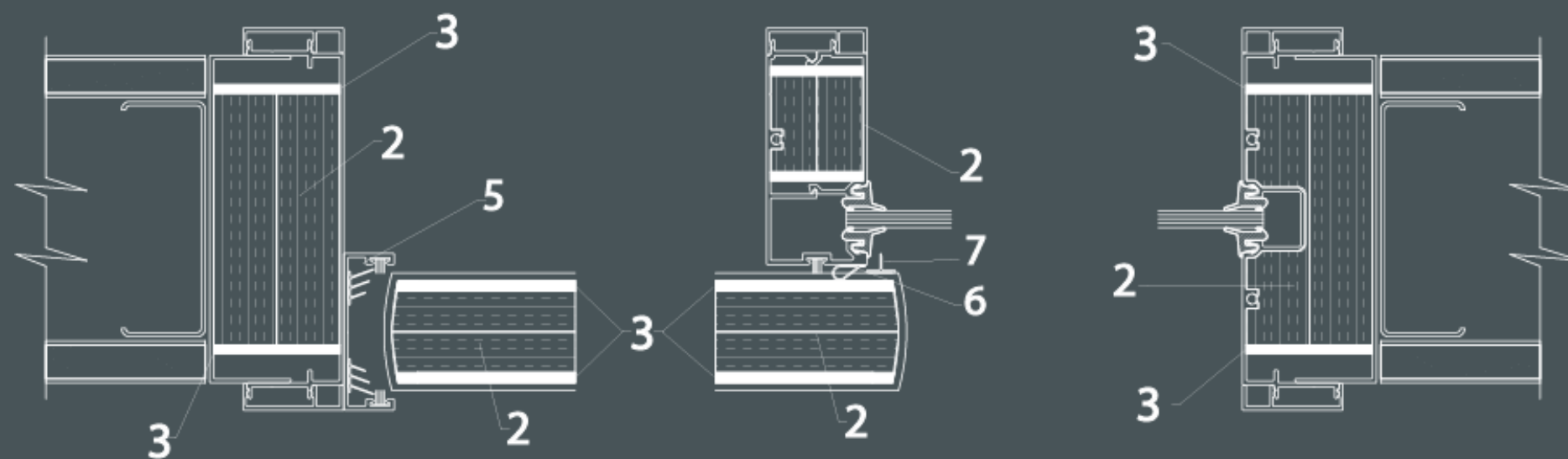

Tested and approved for an STC rating of up to 41 with higher ratings currently pending (VT STC-41 SG4).



Accessibility Compliance

SL9100 ADA Self-Latching Sliding/Pocket

- Single action egress for unlocking & sliding open door in one motion.
- Latch projects & functions like an edge pull when the door hits the frame.
- Self latching, whether latch is projected or retracted.
- The latch bolt held back & released push of a button or sliding closed against the jamb.
- Deadbolt available for locking + extra security.

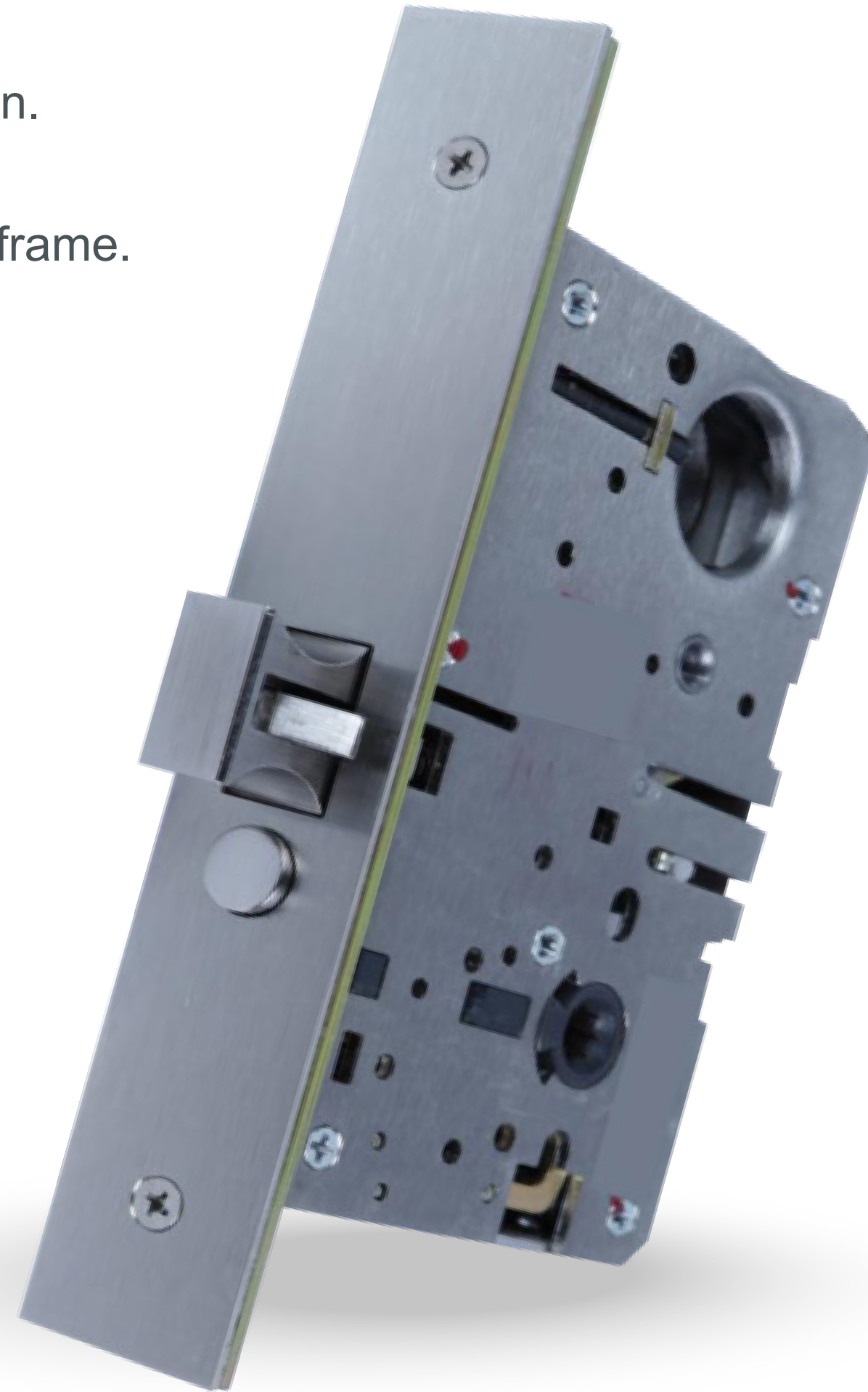

For use with Accurate's SLFT flush pulls (for true pocket door applications) or Accurate's levers. The lock easily installed with other manufacturers' sectional levers (can be installed vertically).

- 2 1/2" or 2 3/4" backset standard, other backsets available as a special order.
- Available with 1" front (for 1 3/8" thick doors, specifically SL9100xx).

Hardware

Planet Door Bottom



Rockwood RM3301 Ladder Pull

The Rockwood door pull is just one of many options available for the ExamGlide system.

Pulls can be provided with custom heights at various diameters.



Hawa EKV Soft Close with Soft Close Activator



Slide Elevations (Outside)

Door Slide (Outside)
DOOR SIDE (OUTSIDE)

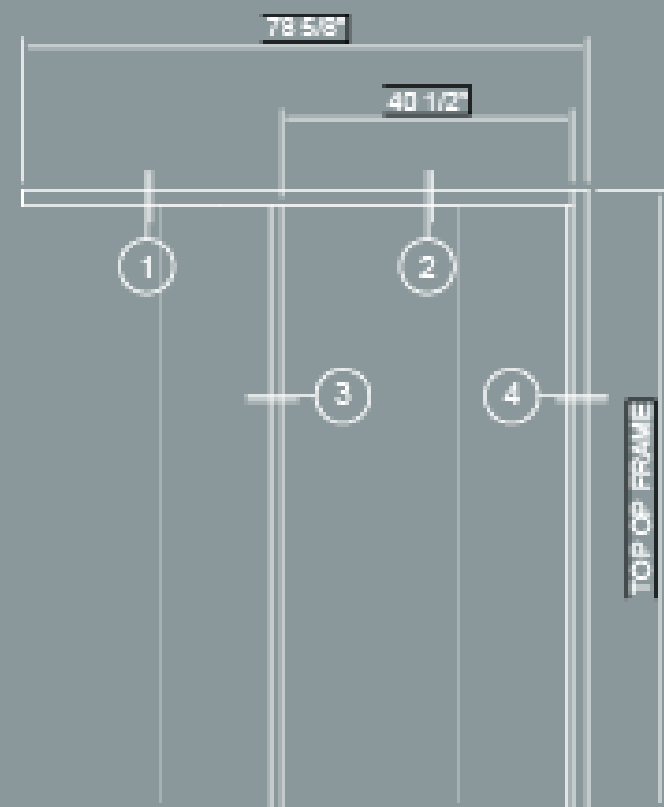

Inside
INSIDE

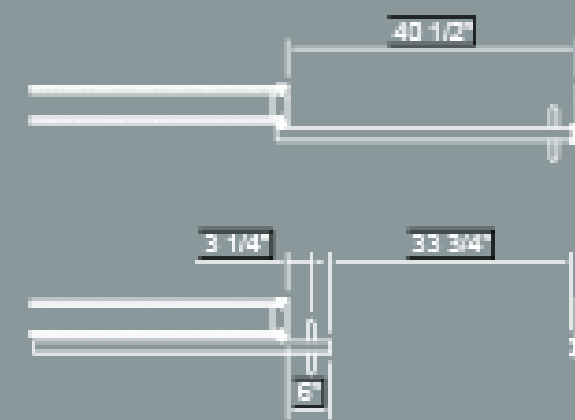
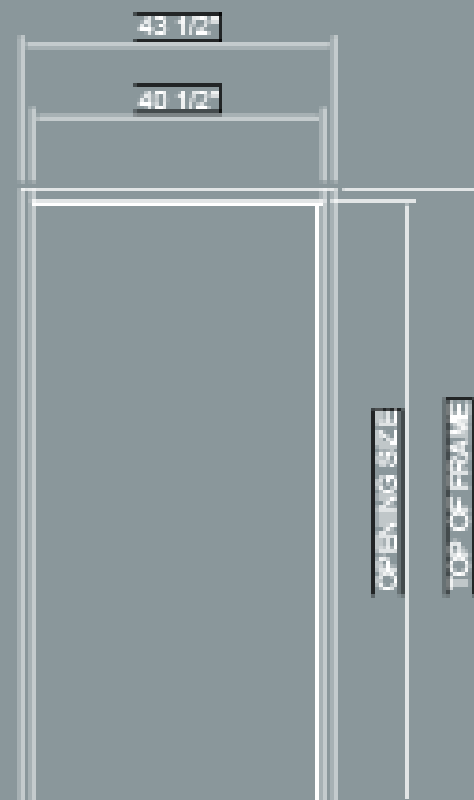

Closed Door
DOOR CLOSED

Open Door
DOOR OPEN

1 Door Track Header on 1-1/2" Trim

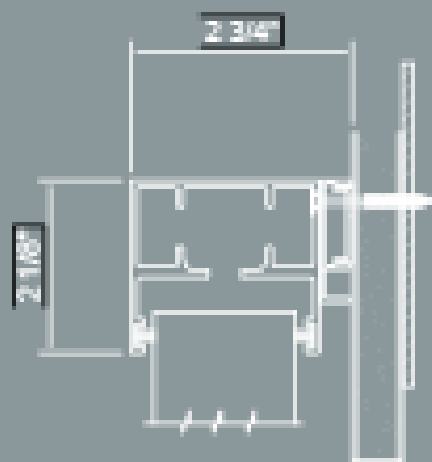

2 Door Track Header on 1-1/2" Trim at Cased Opening

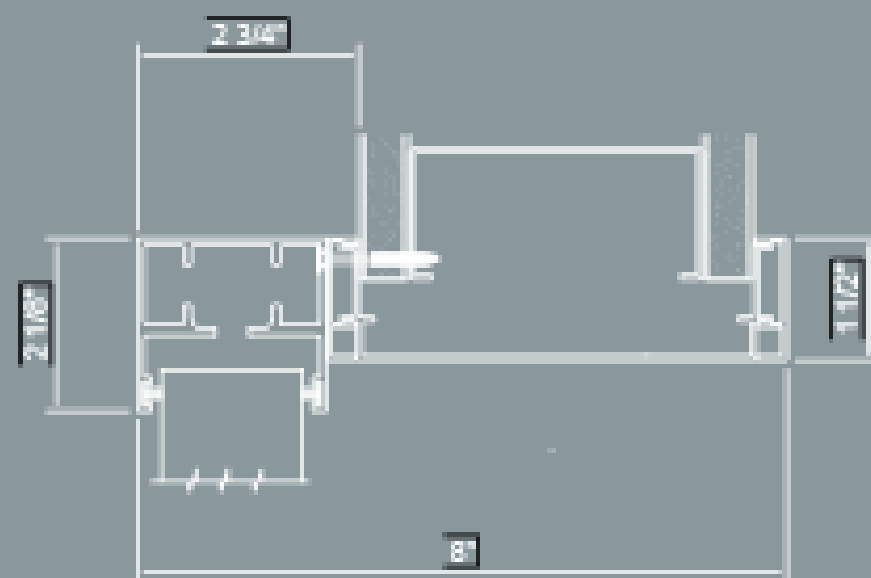

3 Cased Wall Jamb

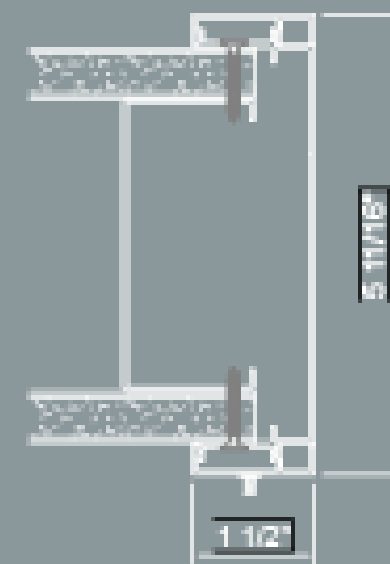

4 Custom Strike Jamb

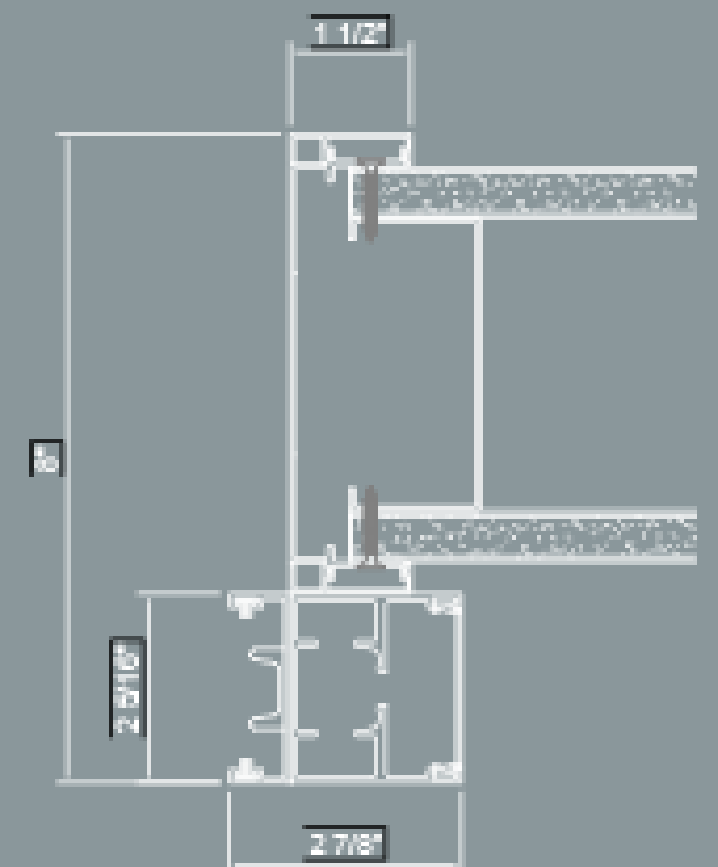

Walters & Wolf Interiors is a team with 40+ years and over 2000 years of combined Industry experience. Our unwavering commitment to quality, continuous improvement, and exceeding customer expectations is demonstrated in our work and backed by a lifetime warranty on our product. Our unique ability to complete on all aspects of a project's life cycle - from design & engineering, through fabrication, installation, and in-house inspection allows for superior quality and a level of commitment that is unparalleled in the Industry. We are a dedicated team that is committed to you for the duration of your project **from concept to completion.**



Just some of our clients who trust the excellence of Walters & Wolf's sliding door systems.

The photos, pictures, contents and products described in this catalogue are for information and guidance purposes only and therefore shall not give rise to any rights or expectations nor constitute a binding sales offer as they are protected by intellectual and industrial property rights in favour of WALTERS & WOLF / Las fotografías, imágenes, contenidos y productos descritos en el presente catalogo tienen carácter exclusivamente ilustrativo y orientativo por lo que no originarán derechos ni expectativas de derechos, ni constituyen una oferta comercial vinculante, resultando protegidos por derechos de propiedad intelectual e industrial a favor de WALTERS & WOLF